

Gemstone™ Vertical Panel

The most space efficient
barricade on the street –
in transit and in storage!

- Designed to withstand repeated impacts with little or no damage to vehicles or unit
- Stackable with or without base
- Available in orange and white
- Recessed panel for reflective sheeting 8" w x 36" h (uses up to 295 in² of sheeting)
- Gemstone side wall provides strength & durability
- Oversized handle with comfort grip
- Flashing light mounting receptacle for standard size bolt and cup washers
- Solid rubber bases with carrying handles come in two sizes: 20 lbs. and 30 lbs.
- NCHRP 350 approved; meets M.U.T.C.D. standards



High Visibility



Gemstone sidewall design
adds strength & durability

PLASTICADE® PRODUCTS

GemstoneTM Vertical Panel

Saves space in use, in transit and in storage!

The most visible and space efficient barricades available, Gemstones take up **half the space** of traditional barricades, which means less storage space taken and a minimal footprint during use. And, composed of the best and most durable materials, Gemstone barriers are made to last – from inclement weather, repeated impacts and sun exposure. Best of all, Gemstones are highly visible as a result of their uniquely large reflective area. This means increased safety and awareness!

Specs	Panel
Composition	Low density polyethylene
Dimensions	44.5"H x 15.375" width at top of panel is 8.625"
Colors	orange or white
Weight	4 lbs
Sheeting Area Dimension	8.125" x 36.375"
Square Inches of Sheeting	295.55 in ²
Reflective sheeting	Available in all grades in these sizes: 8" x 24" 8" x 34" 8" x 36"

Custom sign legends available upon request.



Light weight

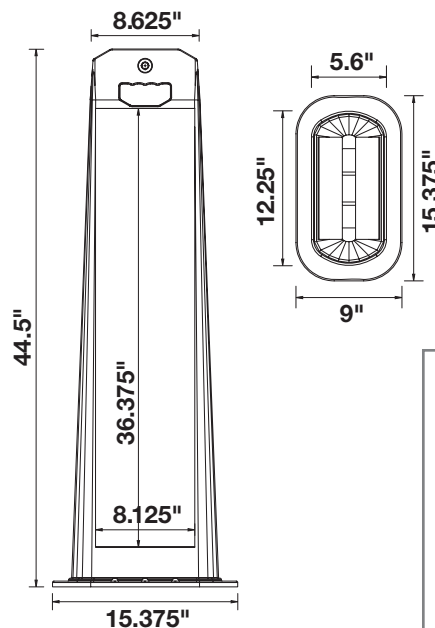

Bases



20 lb. base 30 lb. base

Black rubber bases with carrying handles are made from recycled materials.

PLASTICADE[®] PRODUCTS

MADE IN THE USA
Patents Pending

7700 Austin Avenue
Skokie, IL 60077
phone (800) 772-0355
fax (847) 966-8074

www.plasticade.com